

REVISIONS				
ZONE	REV	DESCRIPTION	Date	APPROVED

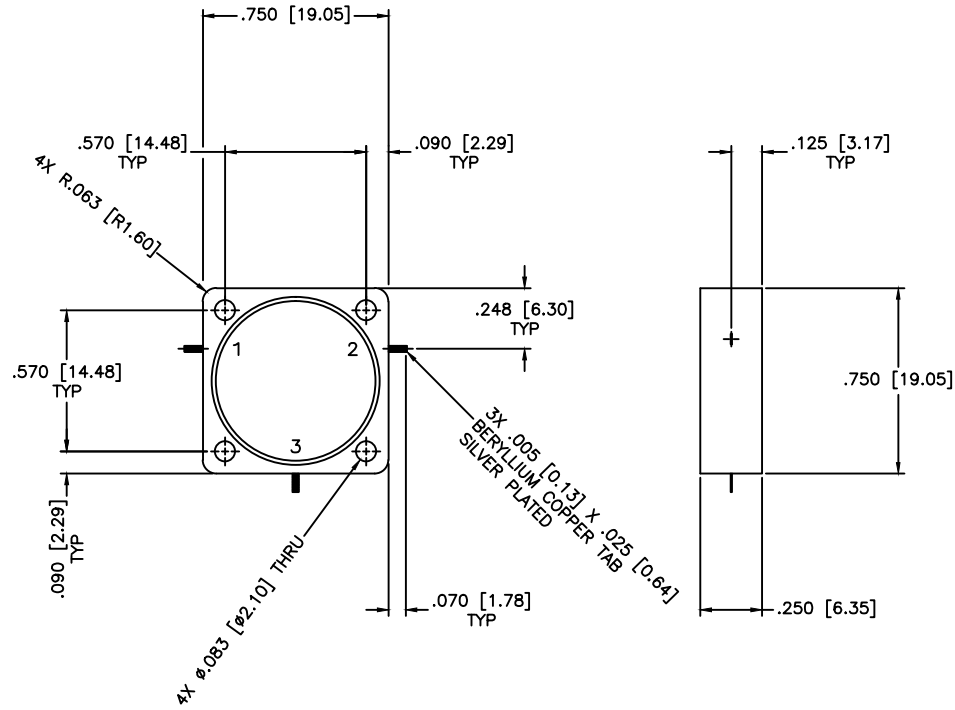

**SPECIFICATIONS**

Frequency Range: 2.7–3.1 GHz  
 Isolation: 20dB Min.  
 Insertion loss: 0.5dB Max.  
 VSWR: 1.25:1 Max.  
 Power: 50W Avg.  
 Operating Temperature: -40°C to +85°C

MATERIAL:		<b>MCLI</b> MICROWAVE COMMUNICATIONS LABORATORIES INC. 7255 30TH AVE. N. SAINT PETERSBURG, FL 33710 TEL: (727) 344-6254 FAX: (727) 381-6116 <a href="http://WWW.MCLI.COM">http://WWW.MCLI.COM</a>	SCALE:	N/A
			SHEET:	N/A
UNLESS OTHERWISE SPECIFIED: TOLERANCES IN (INCHES) OR [mm] (MILLIMETERS) FRACTIONS: ± 1/64 DECIMALS: ±.01 ±.005 ANGLE: ±1/2°		DRAWING TITLE: <b>DROP-IN CIRCULATOR</b>		
DRAWN: Paiboon Luekhamhan		PART NO.: <b>MC-102</b>		
DATE: 03-02-2012		CAGE CODE: OD2L5		
APPROVED: T. Nguyen		SIZE: N/A		
DATE: 03-02-2012		REV: N/A		
THIRD ANGLE PROJECTION		DWG NO.: 86006		
		DO NOT SCALE THE DRAWING		