

**MECHANICAL**

CONTACT: BREAK BEFORE MAKE  
 ACTUATOR: LATCHING  
 SWITCHING SPEED: 20 mSEC MAX

**ELECTRICAL**

ACTUATOR VOLTAGE: 28.0Vdc (22.0-32.0 Vdc)  
 ACTUATOR CURRENT: 300mA MAX @ 28.0Vdc  
 POWER HANDLING: 200W CW @ 1.0GHz  
 IMPEDANCE: 50 Ohms

**ENVIRONMENTAL**

OPERATING TEMP: -54°C to +90°C  
 SINE VIBRATION: 30 G'S rms  
 LIFE: 1,000,000 CYCLES  
 RANDOM VIBRATION: 20 G'S rms

| REVISIONS |     |             |      |          |
|-----------|-----|-------------|------|----------|
| ZONE      | REV | DESCRIPTION | Date | APPROVED |

4X SMA FEMALE  
 3X EQUALLY SPACED AT 120°  
 ON Ø1.062 [Ø26.97] B.C.

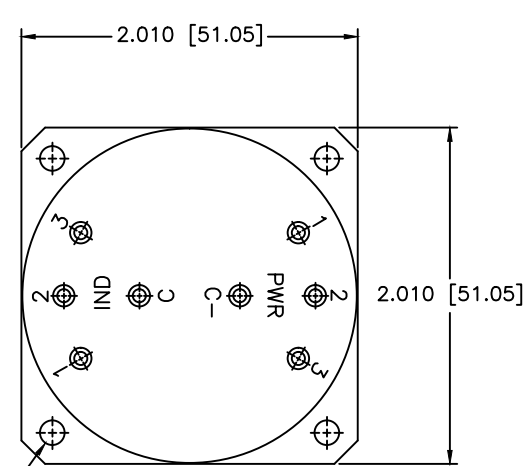
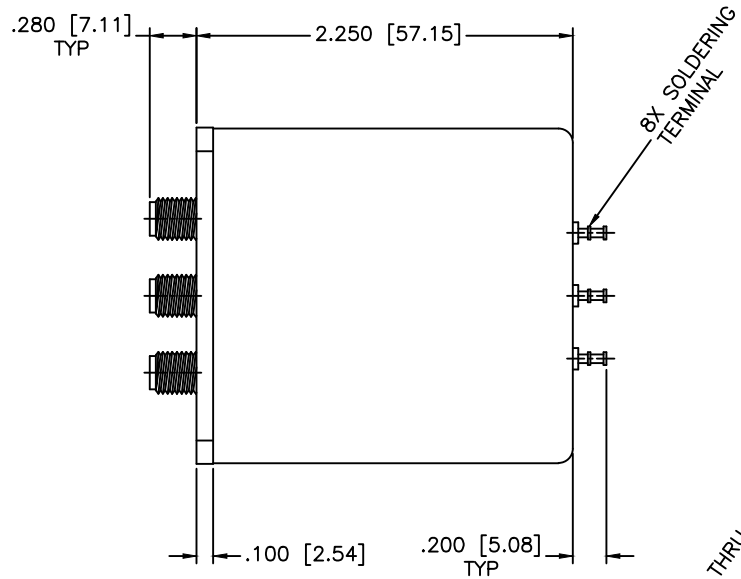
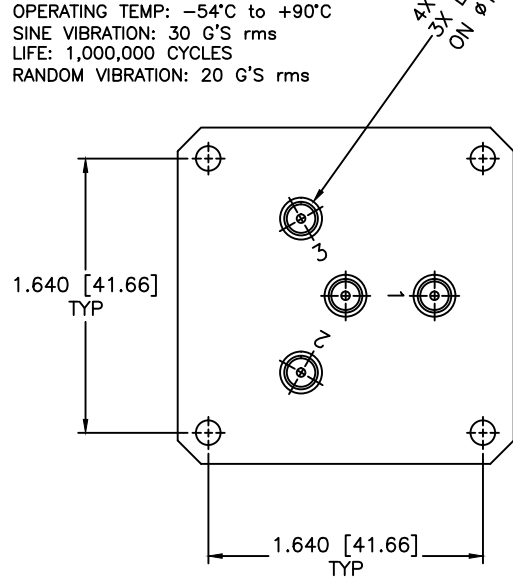

4X Ø.147 [Ø3.73] THRU

**SPECIFICATIONS**  
 Frequency Range: DC-18.0 GHz  
 VSWR: 1.50:1 Max.  
 Insertion Loss: 0.50dB Max.  
 Isolation: 60dB Min.  
 Impedance: 50 Ohms

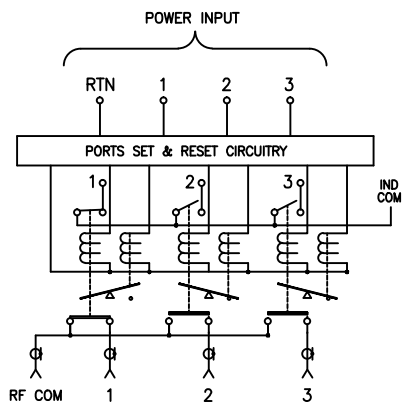

|                                |                     |
|--------------------------------|---------------------|
| MATERIAL:                      |                     |
| DRAWN:<br>Paiboon Luengkhamhan | DATE:<br>02-26-2009 |
| APPROVED:<br>T. Nguyen         | DATE:<br>02-26-2009 |



MICROWAVE COMMUNICATIONS LABORATORIES INC.  
 7255 30TH AVE. N. SAINT PETERSBURG, FL 33710  
 TEL: (727) 344-6254 FAX: (727) 381-6116  
 http://WWW.MCLI.COM

|        |     |
|--------|-----|
| SCALE: | N/A |
| SHEET: | N/A |

UNLESS OTHERWISE SPECIFIED:  
 TOLERANCES  
 IN (INCHES) OR [mm] (MILLIMETERS)  
 FRACTIONS: ± 1/64  
 DECIMALS: ±.02 ±.008  
 ANGLE: ±1/2°

DRAWING TITLE:  
**ELECTROMECHANICAL SWITCHES**

PART NO.  
 03-7-LI

PROSECUTORY NOTICE:  
 THE INFORMATION IN THIS DRAWING IS PROPRIETARY  
 AND SHALL NOT BE USED OR DISCLOSED WITHOUT WRITTEN  
 PERMISSION FROM MICROWAVE COMMUNICATIONS  
 LABORATORIES INC. (MCLI)

THIRD ANGLE PROJECTION

|                          |              |             |                   |
|--------------------------|--------------|-------------|-------------------|
| CAGE CODE:<br>OD2L5      | SIZE:<br>N/A | REV:<br>N/A | DWG. NO.<br>84208 |
| DO NOT SCALE THE DRAWING |              |             |                   |